

Engine	Kohler KWD1003
Rated Power	18 kW (24 hp) @ 3,000 rpm
Nominal Amplitude Range	0.4 mm
Vibration Frequency Range	60 Hz
Centrifugal Force Range	33.5 kN
Working Width	900 mm
Operating Mass	1,700 kg

# 6015E

ROLLER

 **LIUGONG**



TOUGH WORLD. TOUGH EQUIPMENT.

# 6015E SPECIFICATIONS >>>

## ENGINE

Emission Regulation	Tier 3 / Stage III
Make	Kohler
Model	KDW1003
Rated Power	18 kW (24 hp) @ 3,000 rpm
Peak Torque	67 N · m
Number of Cylinders	3
Aspiration	Natural
Cooling Type	Water

## ELECTRICAL SYSTEM

System Voltage	12 V
----------------	------

## DRIVE TRAIN

Theoretical Gradeability	30 %
Transmission Type	Mechanical
Maximum Speed, Fwd	7 km/h
Min. Inside Turning Radius	< 3,500 mm

## AXLES

Steering System	Hydraulic
Steering Method	Articulation
Steering Angle	± 30°
Steering Relief Pressure	16 MPa

## OPTIONAL EQUIPMENT

Rotary Beacon
Backup Alarm

## BRAKES

Service Brake Type	Hydraulic
--------------------	-----------

## HYDRAULIC SYSTEM

Main Pump Type	Piston pump
Main Relief Pressure	20 MPa

## PERFORMANCE

Front Drum Static Linear Load	93 N/cm
Rear Drum Static Linear Load	93 N/cm
Number of Vibrating Drums	2
Nominal Amplitude	0.4 mm
Vibration Frequency	65 Hz
Centrifugal Force	33.5 kN
Number of Amplitude Settings	1

## OPERATING MASS

Operating Mass	1,700 kg
Mass on Steering Drum	850 kg
Mass on Driving Drum	850 kg

## SERVICE CAPACITIES

Fuel Tank	23 L
Engine Oil	4.5 L
Hydraulic Oil Tank	25 L
Cooling System	5 L

## DIMENSIONS

A Overall Length	2,300 mm
B Overall Width	990 mm
C Compaction Width	900 mm
D Wheelbase	1,700 mm
E Tining Angle	30°
G Min. Ground Clearance	210 mm
H Overall Height	2,276 mm

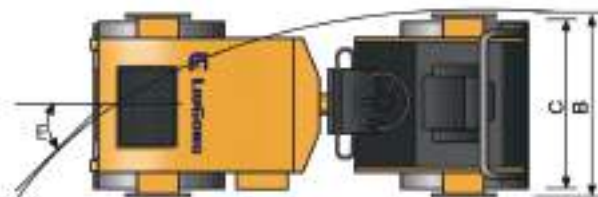
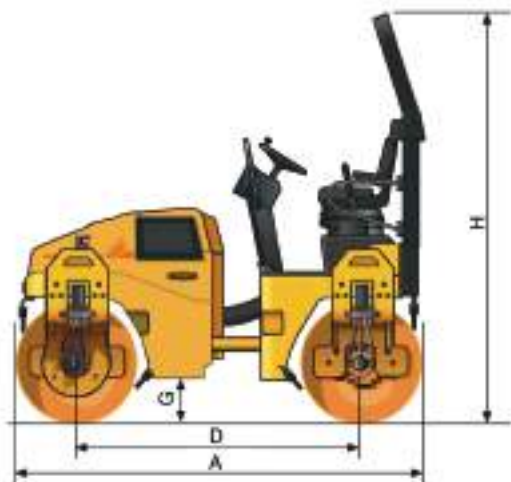

Guangxi Liugong Machinery Co., Ltd.

No. 1 Liutai Road, Liuzhou, Guangxi 545007, PR China  
T: +86 772 3886124 E: overseas@liugong.com  
www.liugong.com

Specifications and designs are subject to change without notice. Machines shown may include optional equipment. Liugong standard and optional equipment may vary from region to region. Please consult your Liugong dealer for information specific to your area.

01/2019 Designed by LiuGong  
Replace the previous versions of 06/2018